

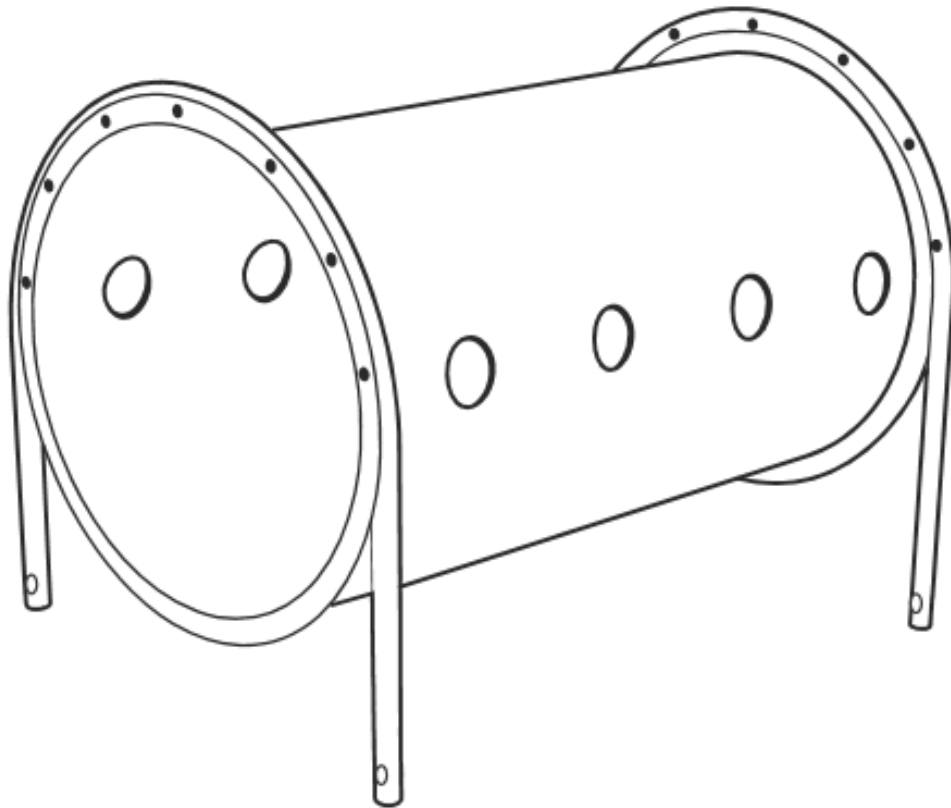

Freestanding Crawl Tunnel

SKU: 622pg615



MOUNTING OPTION 1

Footing Detail for Installations Placed on Ground Level

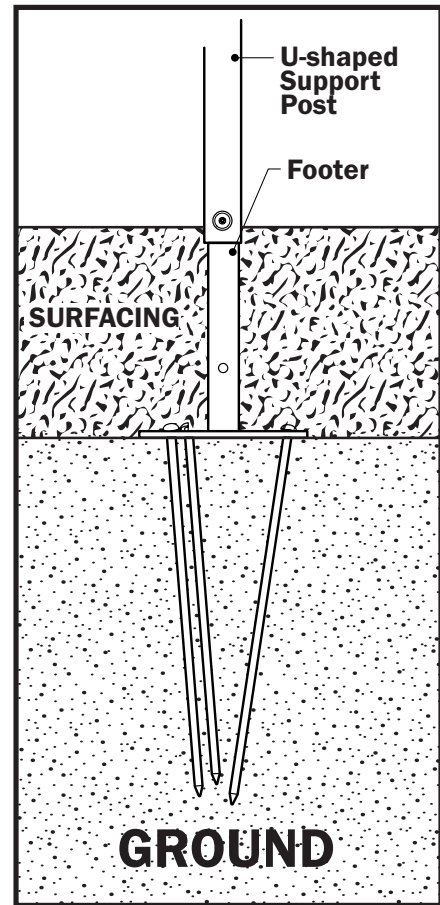
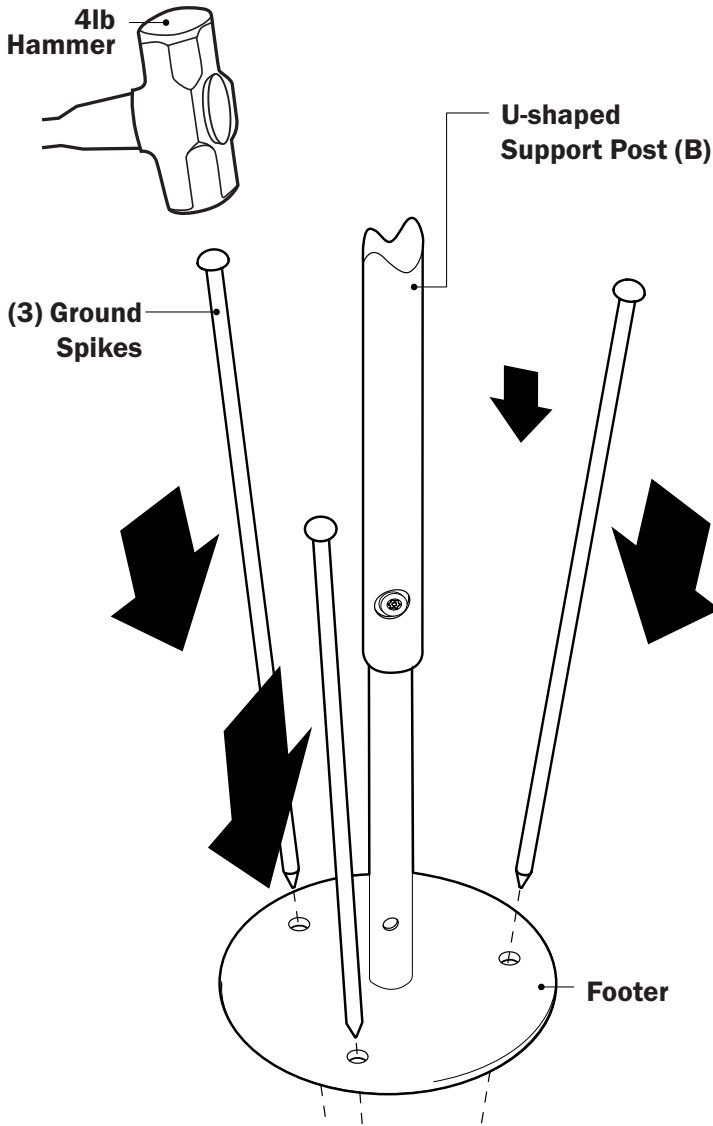

Instructions:

1. With Footers in position, secure each footer to the ground using (3) ground spikes.

NOTE: A 4 lb. hammer may be required to drive spikes into the ground.

IMPORTANT: Never install play equipment over hard, unresilient surfaces such as asphalt, concrete or compacted earth. It is the owner's responsibility to ensure the "minimum area required" contains an appropriate amount of resilient material to cushion accidental falls.

 **Install ground spikes angled inward as shown in illustration.**

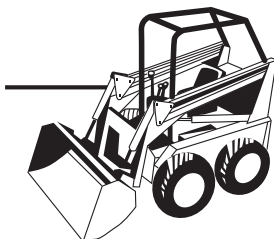

SITE PREPARATION

Clear area of any debris and grade to level surface to +/- 2°

MOUNTING OPTION 2

Footing Detail for Installations Requiring Concrete Footers

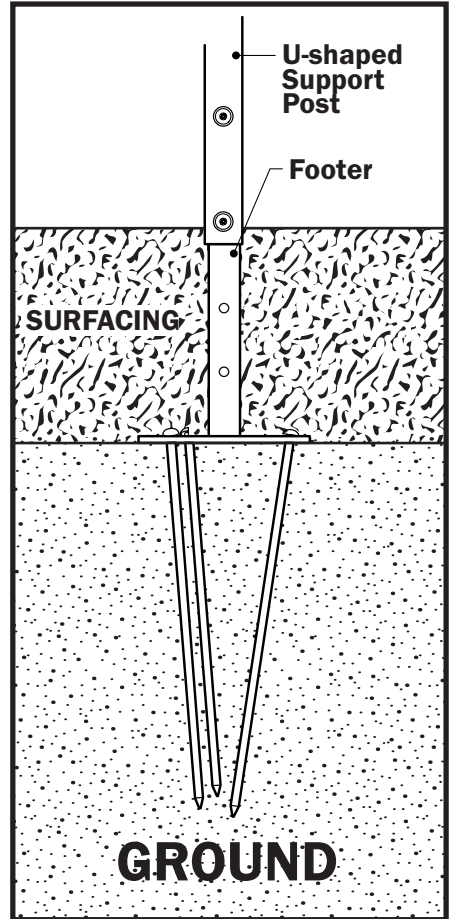
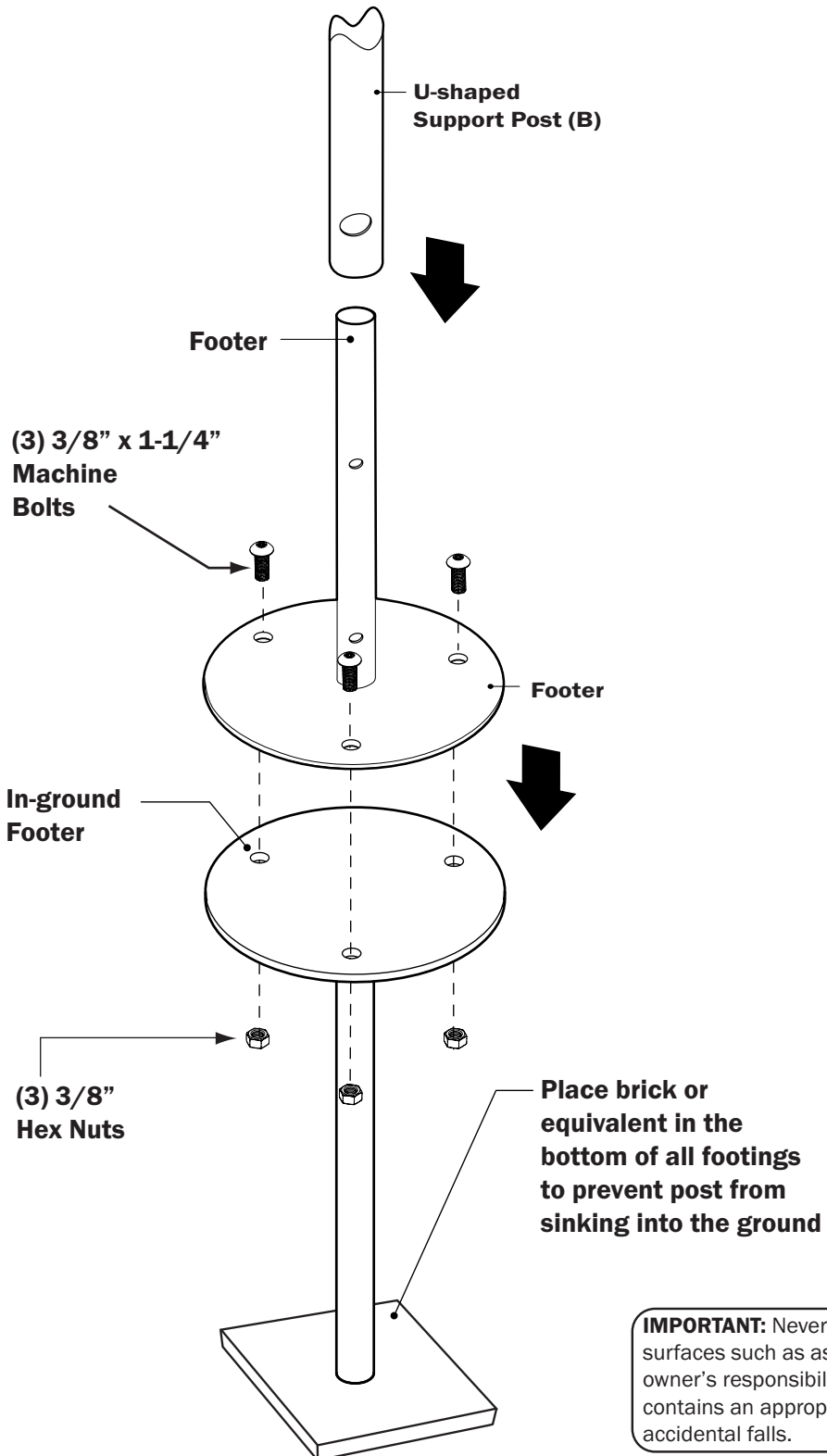

Instructions:

1. Bolt Footer and Inground Footer together using (3) 3/8" x 1-1/4" Machine Bolts and (3) 3/8" Hex Nuts.

IMPORTANT: Never install play equipment over hard, unresilient surfaces such as asphalt, concrete or compacted earth. It is the owner's responsibility to ensure the "minimum area required" contains an appropriate amount of resilient material to cushion accidental falls.

MOUNTING OPTION 2 DETAIL

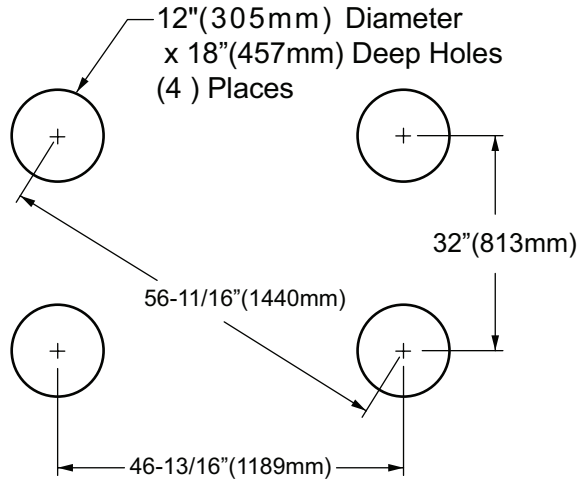

NOTE:

Hole depths indicated on all ground plans are measured from the finished surface. See *Footing Details*.

All Footer dimensions are based on level finished surface.

Concrete Required :

Approx. .18 Cubic Yards (.14 Cubic Meters)

NOTE: Suggested Min. concrete rating: 3000PSI

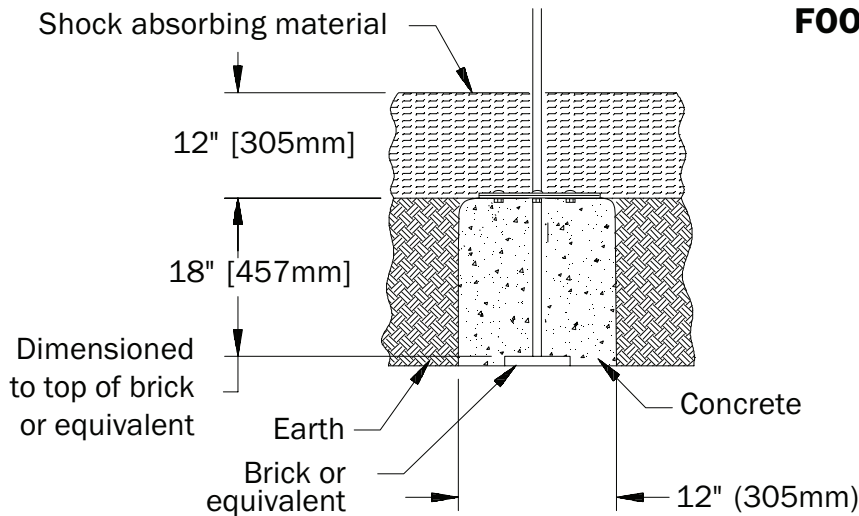

FOOTING DETAIL

NOTE:

Read all installation instructions thoroughly before starting. Bracing material is required while concrete is curing.

Instructions:

1. Dig holes according to the Ground Plan above.
2. Place Crawl Tunnel into holes making sure posts rest on brick. See *Footing Detail*.
3. Level Crawl Tunnel.
4. Pour concrete according to Footing Detail. Allow 48 hours minimum for concrete to cure.

SPECIFICATIONS:

Crawl Tunnel: The 29-1/2" I.D. with 1/4" nominal wall thickness shall be rotationally molded linear low density polyethylene.

Footer Post: Footer Post support shall be fabricated from 1.315" O.D., 14 gauge (.083" wall) galvanized steel tubing and powder coated after fabrication.

Footer: 1" O.D. 14 gauge (.083" wall), galvanized, steel tubing welded to 1/4" thick galvanized steel plate.

Hardware: Primary hardware is stainless steel.

Weight: 90 lbs.

ATTACH FOOTER POSTS TO CRAWL TUNNEL AND FOOTERS

1. Lower U-shaped Support Post(B) behind flange of Crawl Tunnel(A).

2. Insert Bolt(D) through center hole in Crawl Tunnel(A), into Support Post(B) and secure with Barrel Nut(E).

NOTE: Lightly tighten Bolts(D) until all Bolts(D) have been inserted.

3. Repeat Step 2 for remaining Bolts(D).

4. Align hole in Support Post(B) with hole in Footer(C).

NOTE: Use UPPER hole if using EWF (Engineered Wood Fiber)

Use LOWER hole if using 2" rubber tiles or poured-in-place surfacing.

5. Insert Bolt(F) through larger hole in Support Post(B), into Footer(C) and through the other side of Support Post(B) and secure with Lock Nut(G). See Figure 1.

6. Repeat steps 4-5 for Remaining Footers(C).

Parts List			
Letter	Description	Quantity	Part Number
A	Crawl Tunnel	1	02-07-0050
B	Support Post	2	02-07-0087
C	Footer	4	G-01-08-0275
	Hardware Complete	1	33-12-0058
D	5/16" x 1-1/2" BHCS Bolt	14	33-06-0082
E	5/16" Barrel Nut	14	33-01-0029
F	3/8" x 1-1/2" BHCS Bolt	4	33-06-0086
G	3/8" Hex Nut	4	33-01-0018

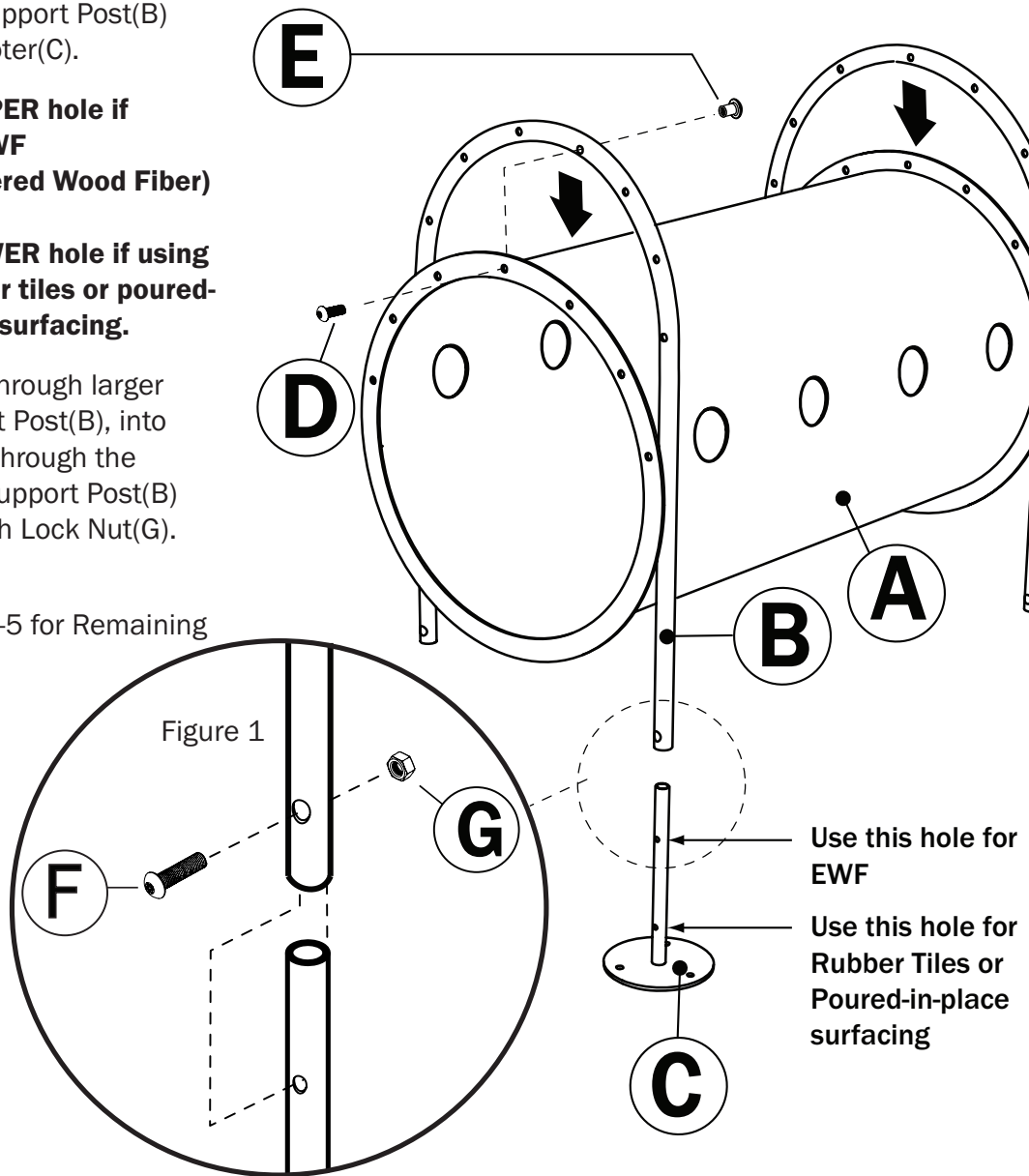

SECURE CRAWL TUNNEL TO GROUND

ABOVE GROUND INSTALLATION

For Above Ground installation using Ground Spikes(A), refer to Mounting Option 1 on page 2.

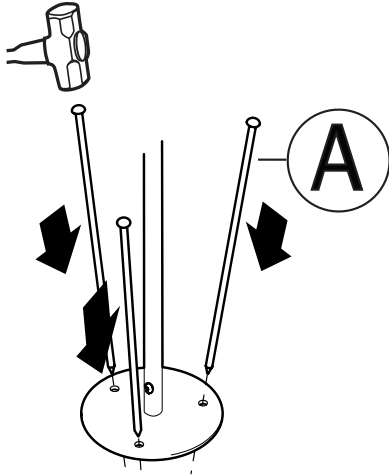

or

IN-GROUND INSTALLATION

For In-Ground installation using the In-ground Footer(B), refer to Mounting Option 2 on pages 3 and 4.

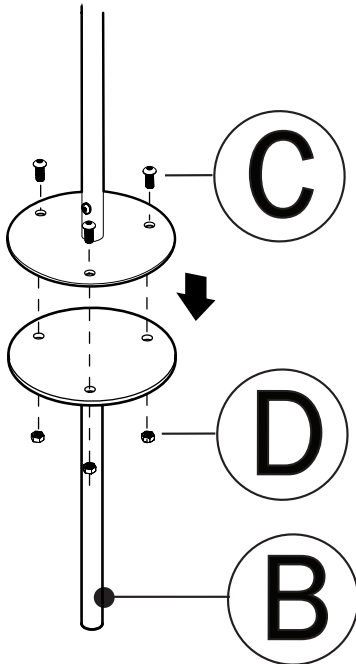

Parts List			
Letter	Description	Quantity	Part Number
A	Ground Spikes	12	02-07-0048
B	In-Ground Footer	4	02-07-0049
	Hardware Complete	1	33-12-0058
C	3/8" x 1-1/4" Machine Bolt	12	33-05-0019
D	3/8" Hex Nut	12	33-01-0002

